



RIVA RACING
PERFORMANCE PRODUCTS & ACCESSORIES

Sea-Doo 4-TEC Stock Retainer Upgrade Kit

PART# - RS19050-SRU-1

APPLICATION(S): All 4-TEC Engines

Please read the following completely prior to beginning installation.

A service manual is recommended when performing this installation. The following instructions were written using our Valve Compression Tool (part# RS19050-VCT). This tool allows you to install our Stock Retainer Upgrade Kit without removing the cylinder head. Please refer to the Rotax 1503 4-TEC Engine Shop Manual to install Stock Retainer Upgrade Kit without using RIVA Valve Compression Tool.

- INSTALLATION INSTRUCTIONS -

1. Remove D.E.S.S. lanyard and disconnect battery cables. **NOTE: Negative (black) first. Positive (red) second.**
2. Remove ignition coils (spark plug caps).
3. Remove plastic cover with BRP logo from valve cover exposing valve cover screws (bolts). Remove 8 screws (bolts) securing valve cover to cylinder head. (see illustration #1)
4. Remove spark plug tubes.
5. Remove rocker arm shaft assembly and discard bolts. (see illustration #2) **NOTE: Before removing mark rocker arm shaft and cylinder head at one end for replacement reference.**
6. Install compression rod supports onto cylinder head using supplied hardware making sure red indicators are aligned with camshaft. (see illustration #'s 3&4)
7. Install supplied airline into spark plug receiver for cylinder being serviced. (see illustration #3) Using a metered airline, pressurize cylinder to **80psi maximum**. **NOTE: When pressurizing cylinder cam chain guide may rise out of cylinder head. Simply hold in place or push back into place.**
8. Insert compression rod into supports and align compression cup with valve. (see illustration #'s 5&6)
9. Tighten compression bolt until compression cup seats on valve spring keeper. (see illustration #6) Check alignment. Tighten compression bolt enough to expose valve spring retainer cotters. (see illustration #7)
10. Remove valve spring retainer cotters (2). (see illustration #8) **TIP: Use a magnet!**
11. Loosen compression bolt completely. Rotate compression rod to allow access to valve.
12. Remove OE valve spring retainer.
13. Install one supplied valve spring retainer.
14. Rotate compression rod and realign compression cup with valve spring retainer. Tighten compression bolt until compression cup seats on valve spring keeper. Check alignment. Tighten bolt enough to expose end of valve shaft.
15. Apply white lithium grease to inside of valve spring retainer cotters (2). Install onto end of valve shaft. (see illustration #11) Loosen compression bolt completely and rotate compression rod to allow access to valve. Thoroughly inspect valve spring assembly to ensure cotters are seated properly. **CAUTION: An improperly locked valve spring will cause engine damage.**
16. Remove compression rod from supports. Rotate 180-degrees and insert into supports for same valve set. (see illustration #11)
17. Repeat steps 9~15 for second valve.
18. Remove compression rod from supports and insert into opposite side for remaining valves. **EG- If procedure began with intake valves you would now modify exhaust valves.** Repeat steps 6~17.
19. After modifying all 4 valves carefully release air pressure from cylinder. Remove supplied air hose.
20. Remove compression rod supports. Repeat steps 6~19 for second and third cylinder.
21. Thoroughly inspect valve train for misaligned valve spring keepers, valve springs and foreign objects.
22. Apply BRP 4-stroke XPS oil to rocker arm shaft.

23. Install rocker arm shaft assembly. **NOTE: Rocker arm shaft assembly can only be installed one way. Use markings applied during step 5.**
24. Secure rocker arm shaft using supplied bolts. **NOTE: Reference illustration# 12 for proper torque sequence.** Torque at first to 7 ft•lbs / 10 N•m. Torque again to 14 ft•lbs / 20 N•m. Finish tightening by turning each bolt an additional 90-degrees. **DO NOT APPLY THREAD LOCK.**
25. Install spark plug tubes.
26. Clean outer edge of cylinder head. Install valve cover making sure sealing ring is properly seated. **NOTE: Reference illustration# 13 for proper torque sequence.** Torque to 7 ft•lbs / 10 N•m. **DO NOT APPLY THREAD LOCK.**
27. Install plastic cover with BRP log onto valve cover.
28. Install ignition coils (spark plug caps).
29. Reconnect battery cables. **NOTE: Positive (red) first. Negative (black) second.**

Remember, the water belongs to everyone. Please ride responsibly!

Technical Support

For answers to questions regarding installation or trouble shooting RIVA Performance Products contact: RIVA Technical Support directly at (954) 247-0705 or by e-mail at tech_support@rivamotorsports.com

Limited Warranty

RIVA Stock Retainer Upgrade Kits carry a 30-day limited warranty to the original purchaser. They are warranted to be free of defects in materials and workmanship under normal use and service. Customer modified components will be void of warranty. This warranty is limited to defects in the primary components only. Finish and/or wear marks in or on primary components are not covered under this warranty.

RIVA Racing's liability is expressly limited to the repair or replacement of the components contained within or associated with this kit. RIVA Racing agrees to repair or at RIVA's option, replace any defective unit without charge, if product is returned to RIVA Racing freight prepaid within the warranty period. Any equipment returned which, in RIVA's opinion, has been subjected to misuse, abuse, overheating or accident shall not be covered by this warranty.

RIVA Racing shall have no liability for special, incidental or consequential damages or injury to persons or property from any cause arising from the sale, installation or use of this product.

No other warranty, express or implied, including, but not limited to the implied warranties of merchantability and fitness for a particular purpose, applies. Various states do not allow for the limitation of incidental or consequential damages and therefore the above exclusion or limitation may not apply to you.

Warranty does not include the expenses related to freight or transportation of parts or compensation for any inconvenience or loss of use while being repaired. A copy of the original invoice must accompany all warranty claims.

Warranted replacement parts will be returned freight collect.

- INSTALLATION IMAGES -

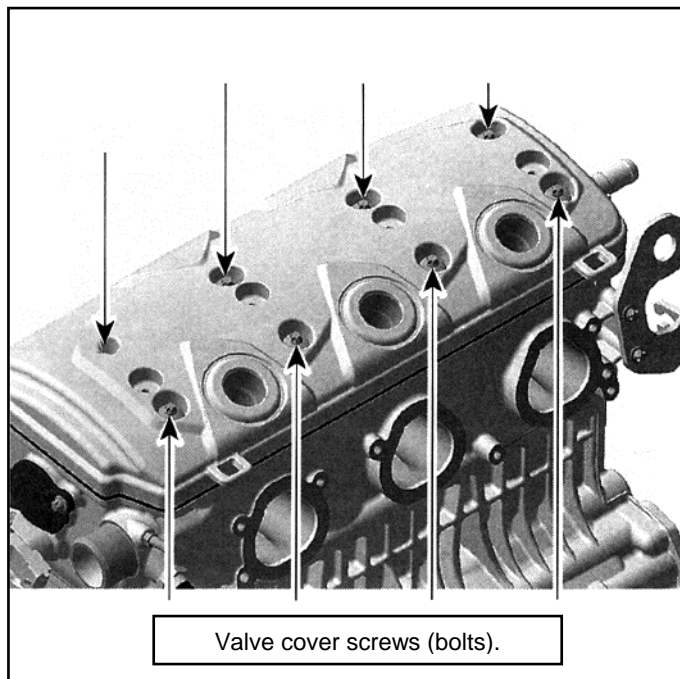

Illustration #1

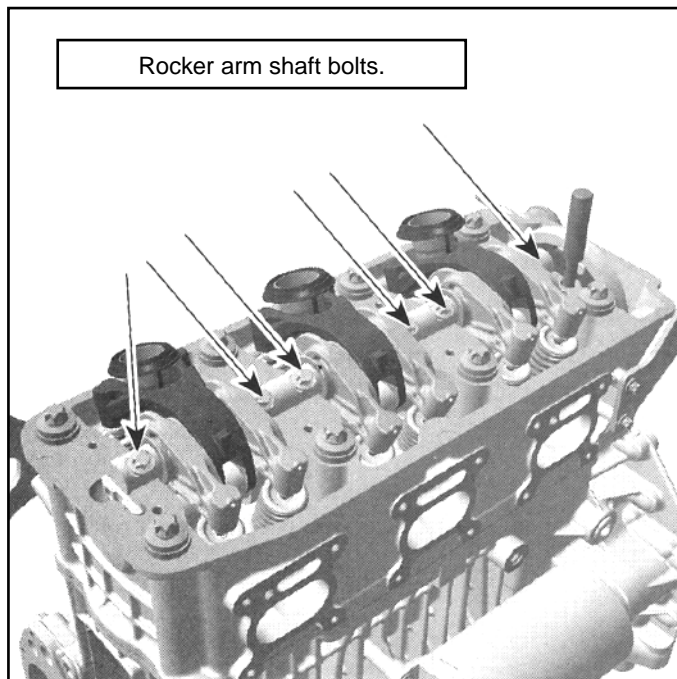

Illustration #2

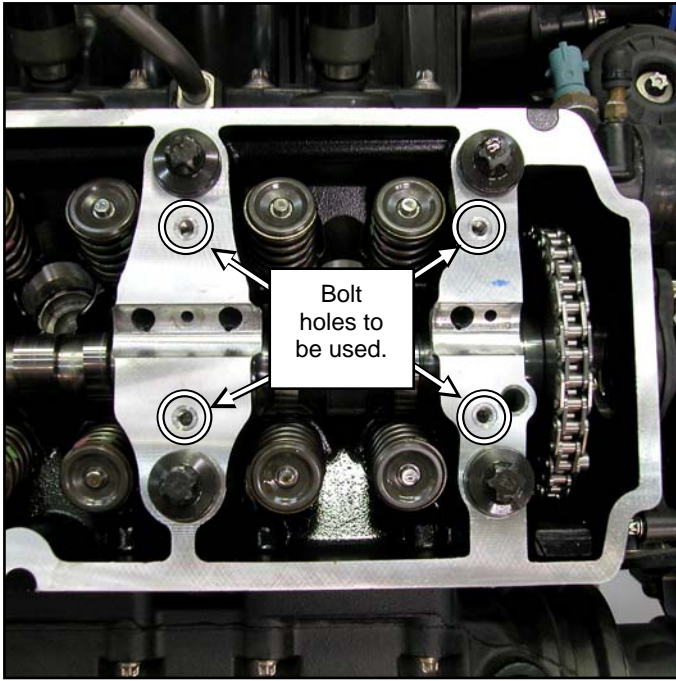

Illustration #3

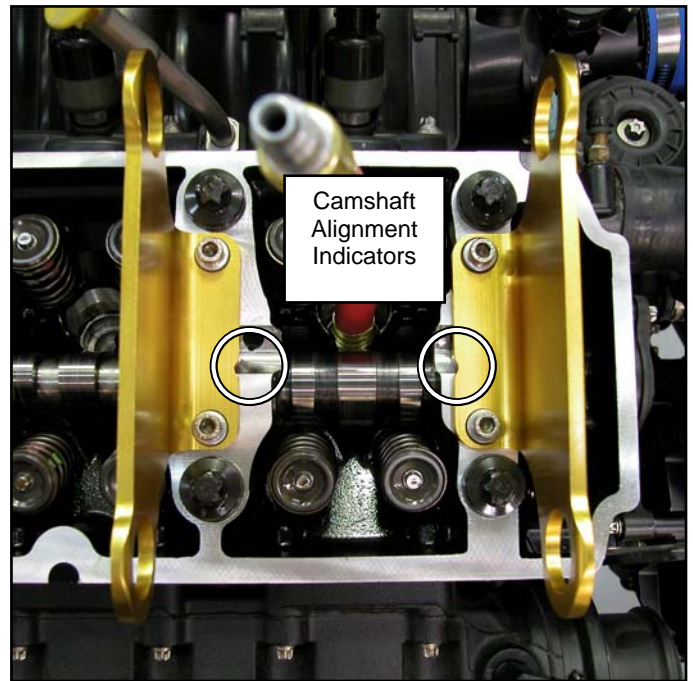

Illustration #4

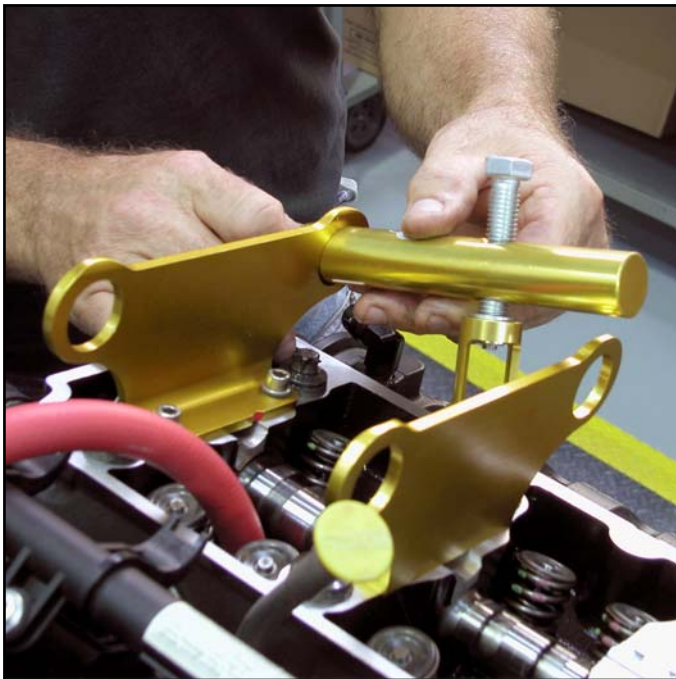

Illustration #5

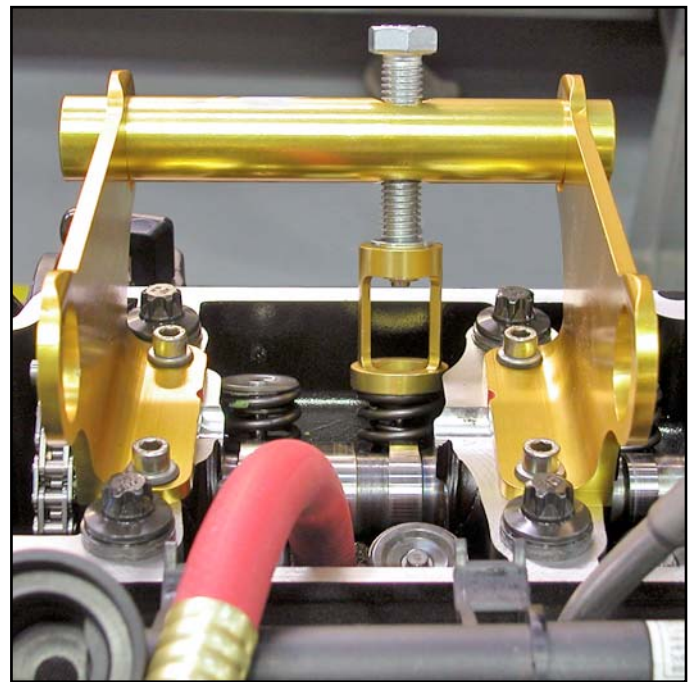

Illustration #6

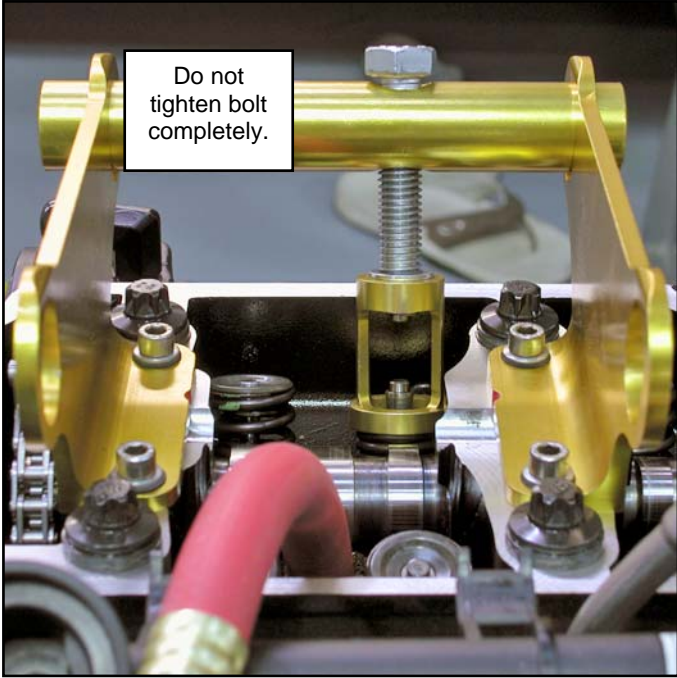

Illustration #7

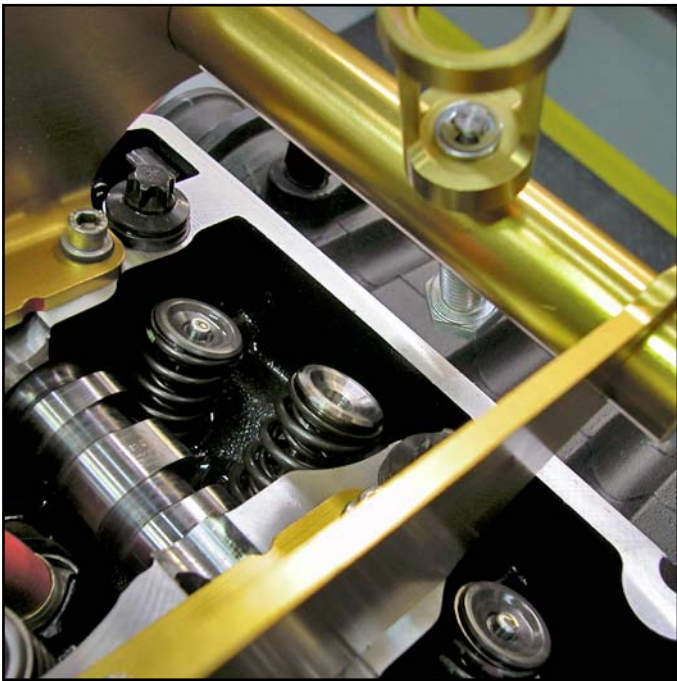
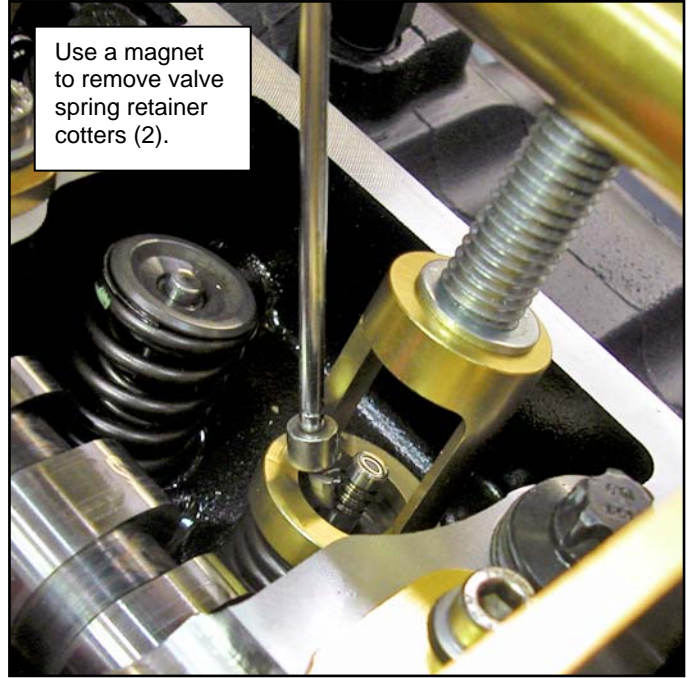

Illustration #9

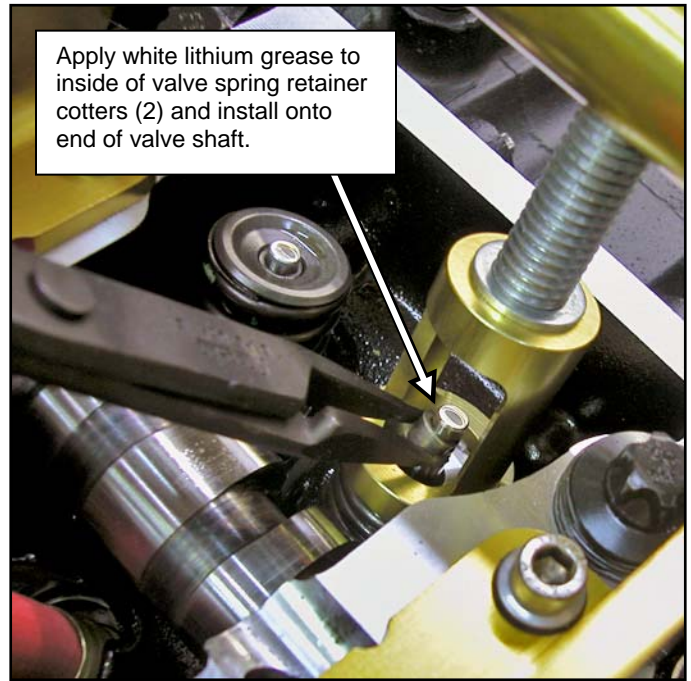

Illustration #10

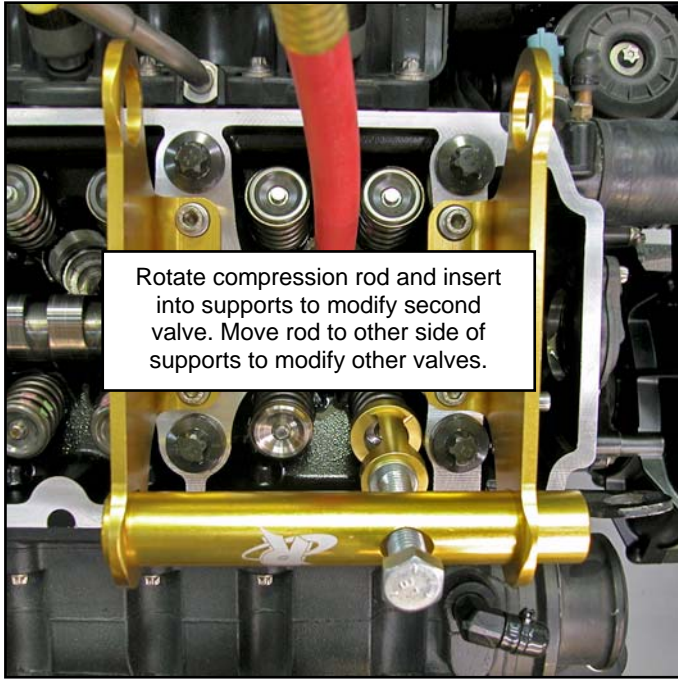

Illustration #11

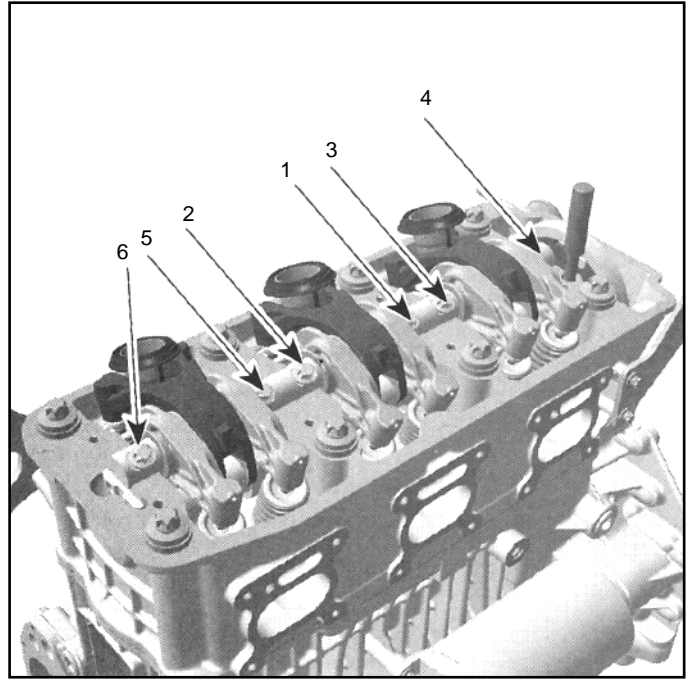

Illustration #12

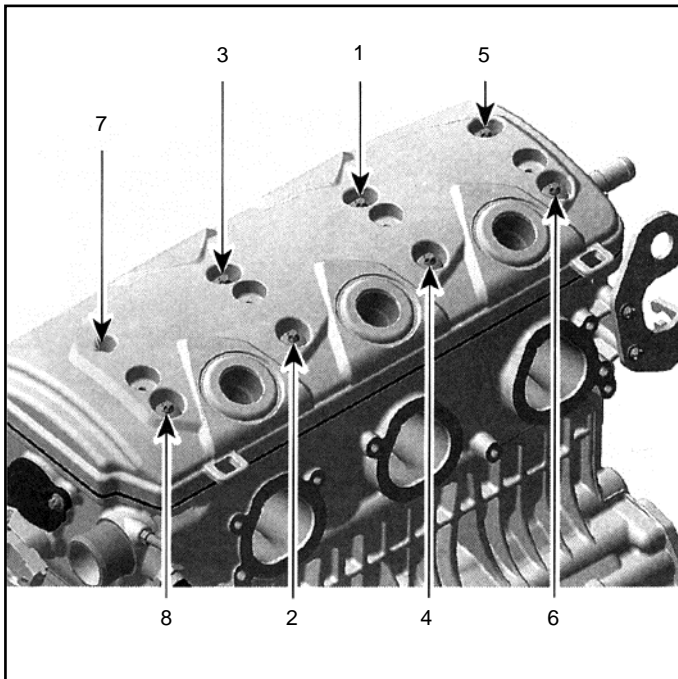

Illustration #13