



RIVA RACING

PERFORMANCE PRODUCTS & ACCESSORIES

Yamaha 1.8L SVHO/SHO Vacuum Port Adapter

RY12110-VPA



Applications: Yamaha 1.8L SVHO & SHO Engines

Approximate Installation Time: 0.5hrs

Recommended Specialty Tools:

N/A

Part #

Required Materials:

Permatex Thread Sealant w/PTFE

Part #

N/A



Yamaha 1.8L Vacuum Port Adapter

RY12110-VPA

COMPONENT LIST

Item	Description	Qty. Req.	Notes
A	BILLET ADAPTER BLOCK	1	Secured together for packaging.
B	MALE/FEMALE SENSOR FITTING	1	
C	CRUSH WASHER	2	
D	1/8" NPT BLOCK-OFF FITTING	2	
E	1/8" NPT X 1/8" BARBED STRAIGHT FITTING	1	
F	1/8" NPT X 1/4" BARBED STRAIGHT FITTING	1	
G	ZIP TIE	2	

Notes and Precautions

We strongly recommend the use of a service manual to familiarize yourself with the various components and procedures involved with this installation. Please note that some of the original hardware removed in the disassembly process will be used in the installation process. These instructions have been written in step-by-step format and refer to illustrations. Read through instructions entirely before performing installation. Please follow these step-by-step instructions and illustrations carefully.

***** ALLOW ENGINE TO COOL COMPLETELY BEFORE PERFORMING INSTALLATION *****

***** NO SMOKING *** NO SMOKING *** NO SMOKING *****

CAUTION: Whenever using electric or battery operated tools inside the hull be sure it is well ventilated and no fumes are present. Failure to do so could result in a fire, or explosion and serious personal injury or death.

Your kit was inspected and verified before being carefully packaged by our staff. Please check package contents before beginning assembly. If you have a question about missing or damaged items please contact RIVA Technical Support directly at (954) 247-0705 or by e-mail at tech_support@rivaracing.com.

Installation Instructions

On the engine's intake manifold, locate Intake Temperature Sensor fitting. (See Figures 1A or 1B)

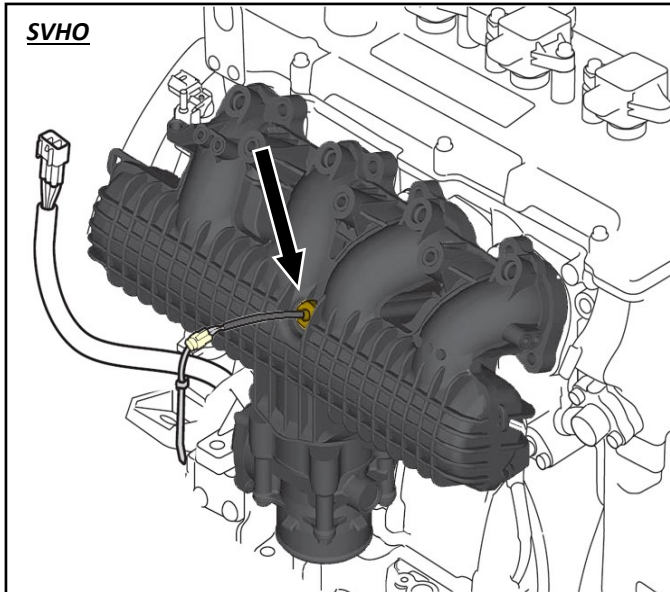

Figure 1A

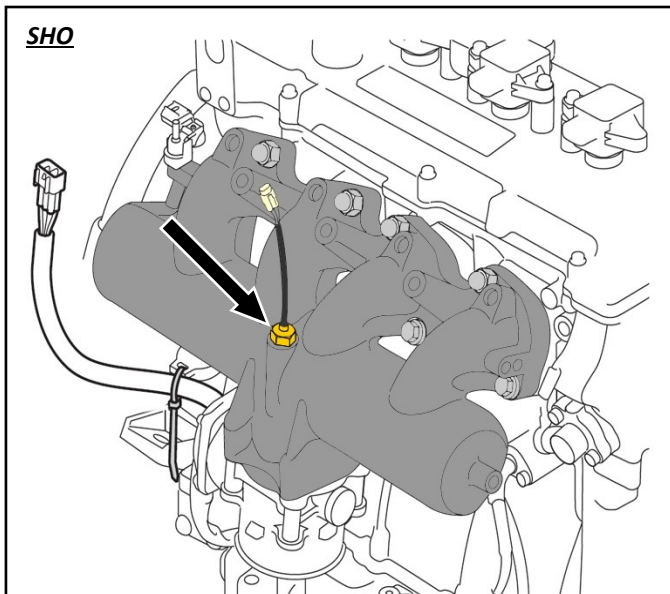

Figure 1B

Disconnect electrical wires at connector.

Remove Intake Temperature Sensor fitting from intake manifold. Remove OEM washer from sensor fitting.

Separate the brass male/female sensor fitting from the Billet Adapter Block and crush washers. Install washer from Intake Temperature Sensor onto end with male threads. Apply thread sealant with PTFE to male threads and install into intake manifold where Intake Temperature Sensor fitting was located previously. **NOTE: DO NOT overtighten.** (See Figure 2)



Figure 2

Install one supplied crush washer onto male/female sensor fitting and place supplied Billet Adapter Block onto fitting. Determine which fitting locations will work best for your boost/vacuum line configuration. Remove Billet Adapter Block and install applicable supplied barbed fitting(s) and block-off fitting(s). **NOTE: Apply thread sealant with PTFE to threads. DO NOT overtighten. NPT fittings are tapered.**

Install Billet Adapter Block onto male/female sensor fitting again. Install second supplied crush washer onto Intake Temperature Sensor fitting. Apply thread sealant with PTFE to threads and install. **NOTE: Make sure crush washer is centered on male/female brass fitting. Do not overtighten Intake Temperature Sensor.** (See Figure 3)



Figure 3

Installation Instructions

Reconnect Intake Temperature Sensor.

Install boost/vacuum line(s) onto fitting(s) and secure with supplied zip tie(s). (See Figure 4)



Figure 4

Remember, the water belongs to everyone.

Please ride responsibly and respect the environment!

Technical Support

For answers to questions regarding installation or trouble shooting RIVA Performance Products contact:

RIVA Technical Support directly at (954) 247-0705 or by e-mail at tech_support@rivaracing.com.

Limited Warranty

RIVA Vacuum Port Adapter Kits carry a 90-day limited warranty to the original purchaser. They are warranted to be free of defects in materials and workmanship under normal use and service. Customer modified components will be void of warranty. This warranty is limited to defects in the primary components only. Finish and/or wear marks in or on primary components are not covered under this warranty.

RIVA Racing's liability is expressly limited to the repair or replacement of the components contained within or associated with this kit. RIVA Racing agrees to repair or at RIVA's option, replace any defective unit without charge, if product is returned to RIVA Racing freight prepaid within the warranty period. Any equipment returned which, in RIVA's opinion, has been subjected to misuse, abuse, overheating or accident shall not be covered by this warranty.

RIVA Racing shall have no liability for special, incidental or consequential damages or injury to persons or property from any cause arising from the sale, installation or use of this product.

No other warranty, express or implied, including, but not limited to the implied warranties of merchantability and fitness for a particular purpose, applies. Various states do not allow for the limitation of incidental or consequential damages and therefore the above exclusion or limitation may not apply to you.

Warranty does not include the expenses related to freight or transportation of parts or compensation for any inconvenience or loss of use while being repaired. A copy of the original invoice and a Return Authorization Number (RA#) must accompany all warranty claims.